



A16062 Series

Size: 160x160x62mm (6.30"x6.30"x2.44")

DIMENSION

HOUSING : Die - Cast Aluminum, Painted Black
 IMPELLER : Injection Molded of Flame Retardant Polycarbonate, Black
 BEARING : Ball
 TERMINATION : Terminals or Lead Wire
 MOTOR TYPE : AC Induction Capacitor Motor
 DIELECTRIC STRENGTH : 1,500 VAC for 1 minute
 INSULATION : Class B
 INSULATION RESISTANCE : 100,000 Ohms min. @500 VDC
 OPERATING TEMPERATURE : -20°C to + 80°C
 SAFETY : Thermally Protected (Auto Restart)
 WEIGHT : 1.4Kg (3.09 lb)

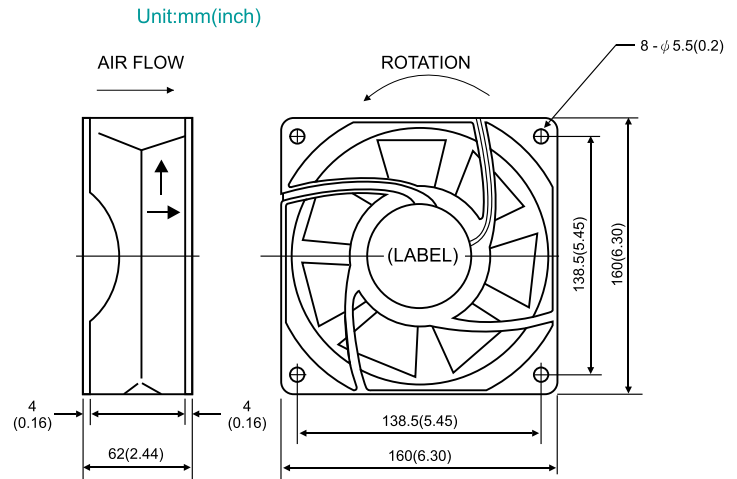

AIR PERFORMANCE

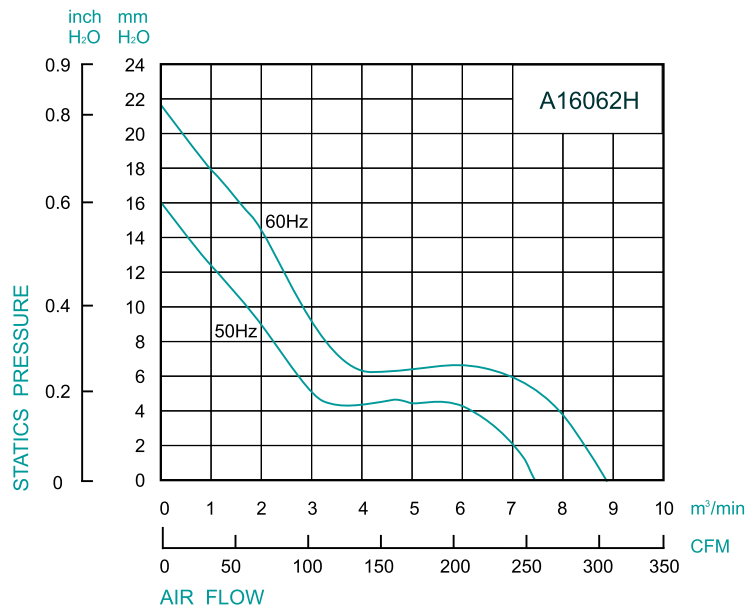

SPECIFICATION

MODEL NO.	RATED VOLTAGE (V)	FREQUENCY (Hz)	RATED CURRENT (A)	INPUT POWER (W)	SPEED (RPM)	AIR FLOW		NOISE dB(A) @ 1M
						CFM	m ³ /min	
A16062V1H	115	50 / 60	0.38 / 0.49	45 / 60	2900 / 3400	266 / 315	7.55 / 8.92	50 / 54
A16062V2H	230	50 / 60	0.19 / 0.27	44 / 60	2900 / 3400	266 / 315	7.55 / 8.92	50 / 54